

The following diagrams introduce the 5 interlocking shapes of the major scale based upon the 5 root patterns found in the C, A, G, E and D shape chords

You will see that a knowledge of the root shapes will enable you to build major scales across the fretboard. The examples are given in the key of A major, these shapes can be applied to any key, simply find the root of the major key you want play in and move the boxes to suit.

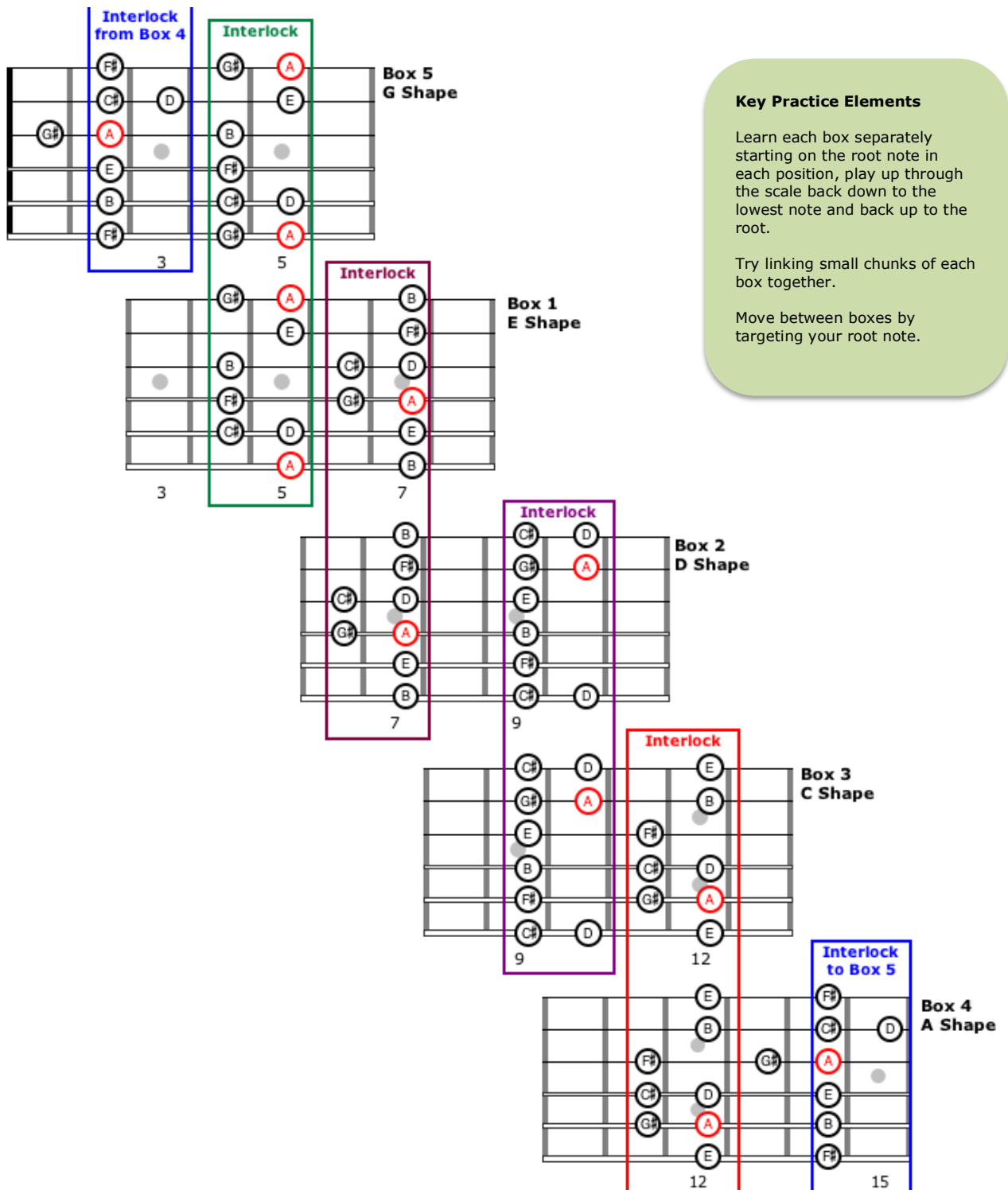

**Key Practice Elements**

Learn each box separately starting on the root note in each position, play up through the scale back down to the lowest note and back up to the root.

Try linking small chunks of each box together.

Move between boxes by targeting your root note.

**Scale Fingering**

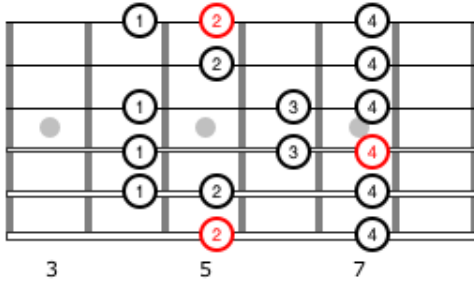

**Box 1**  
**E shape of the CAGED system**

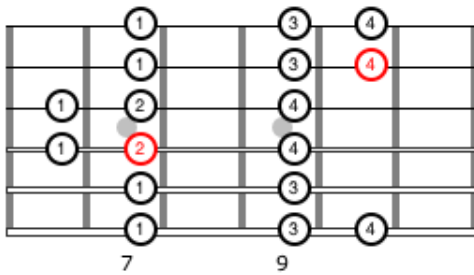

**Box 2**  
**D shape of the CAGED system**

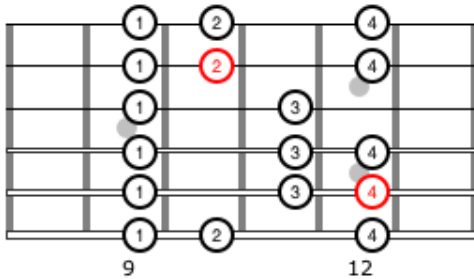

**Box 3**  
**C shape of the CAGED system**

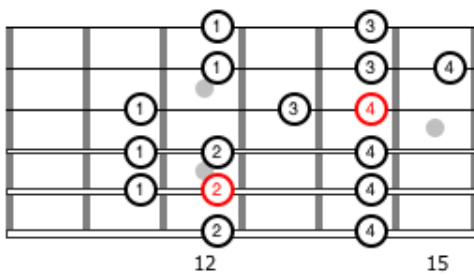

**Box 4**  
**A shape of the CAGED system**

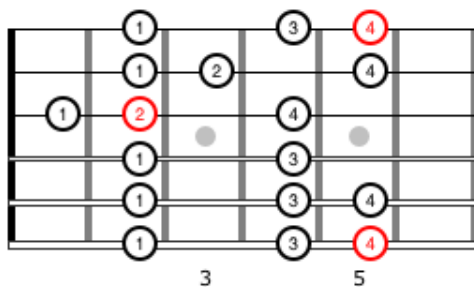

**Box 5**  
**G shape of the CAGED system**

If you review lesson LS006 you will see that this is shape 1 of the natural minor scale simply move the root to the 2<sup>nd</sup> Fret and play the same shape. This is because all scales start life as the major scale.